

125°C Use, Long Life Capacitors Series RK

- Guarantees 5000 hours at 125°C. (ø 8: 2000 hours, ø 10: 3000 hours).
- Best-suited to smoothing circuits and control circuits for industrial equipment power supplies of which long life and high reliability are required.

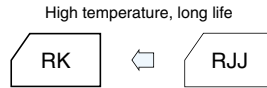

Marking color : White print on a black sleeve

Specifications

Item	Performance														
Category temperature range (°C)	-40 to +125														
Tolerance at rated capacitance (%)	±20 (20°C, 120Hz)														
Leakage current (µA)	Less than 0.04CV (after 2 minutes) C: Rated capacitance(µF); V: Rated voltage(V) (20°C)														
Tangent of loss angle (tanδ)	<table border="1"> <tr> <th>Rated voltage (V)</th> <td>10</td> <td>16</td> <td>25</td> <td>35</td> <td>50</td> <td>63</td> </tr> <tr> <th>tanδ (max.)</th> <td>0.20</td> <td>0.16</td> <td>0.14</td> <td>0.12</td> <td>0.10</td> <td>0.09</td> </tr> </table>	Rated voltage (V)	10	16	25	35	50	63	tanδ (max.)	0.20	0.16	0.14	0.12	0.10	0.09
	Rated voltage (V)	10	16	25	35	50	63								
tanδ (max.)	0.20	0.16	0.14	0.12	0.10	0.09									
0.02 is added to every 1000µF increase over 1000µF. (20°C, 120Hz)															
Characteristics at high and low temperature	<table border="1"> <tr> <th>Impedance ratio (max.)</th> <td>Z-40°C / Z+20°C</td> <td>3 or less</td> </tr> </table> (120Hz)	Impedance ratio (max.)	Z-40°C / Z+20°C	3 or less											
Impedance ratio (max.)	Z-40°C / Z+20°C	3 or less													
Endurance (125°C) (Applied ripple current)	<table border="1"> <tr> <th>Test time</th> <td>5000 hours (ø 10: 3000 hours, ø 8: 2000 hours)</td> </tr> <tr> <th>Leakage current</th> <td>The initial specified value or less</td> </tr> <tr> <th>Percentage of capacitance change</th> <td>Within ±30% of initial value</td> </tr> <tr> <th>Tangent of the loss angle</th> <td>300% or less of the initial specified value</td> </tr> </table>	Test time	5000 hours (ø 10: 3000 hours, ø 8: 2000 hours)	Leakage current	The initial specified value or less	Percentage of capacitance change	Within ±30% of initial value	Tangent of the loss angle	300% or less of the initial specified value						
	Test time	5000 hours (ø 10: 3000 hours, ø 8: 2000 hours)													
	Leakage current	The initial specified value or less													
	Percentage of capacitance change	Within ±30% of initial value													
Tangent of the loss angle	300% or less of the initial specified value														
Shelf life (125°C)	<table border="1"> <tr> <th>Test time</th> <td>1000 hours</td> </tr> <tr> <th>Leakage current</th> <td>The initial specified value or less</td> </tr> <tr> <th>Percentage of capacitance change</th> <td>Within ±30% of initial value</td> </tr> <tr> <th>Tangent of the loss angle</th> <td>300% or less of the initial specified value</td> </tr> </table>	Test time	1000 hours	Leakage current	The initial specified value or less	Percentage of capacitance change	Within ±30% of initial value	Tangent of the loss angle	300% or less of the initial specified value						
	Test time	1000 hours													
	Leakage current	The initial specified value or less													
	Percentage of capacitance change	Within ±30% of initial value													
Tangent of the loss angle	300% or less of the initial specified value														
Voltage application treatment															
Applicable standards	JIS C5101-1, -4 1998 (IEC 60384-1 1992, -4 1985)														

Outline Drawing

Unit: mm

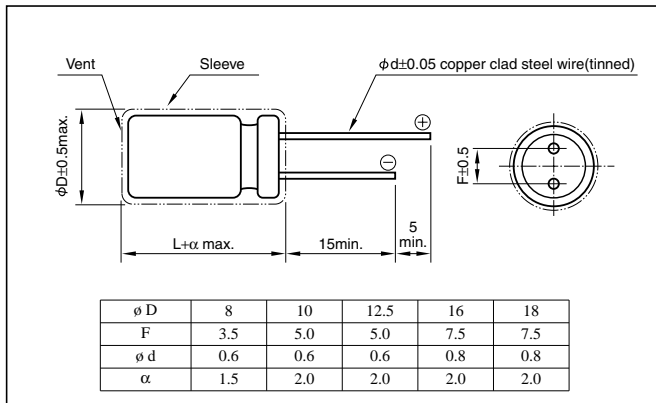

- The electric characteristics are described on page 107.

Coefficient of Frequency for Rated Ripple Current

Rated capacitance(µF)	Frequency(Hz)			
	120	1k	10k	100k
47 to 100	0.40	0.75	0.90	1
220 to 330	0.50	0.85	0.95	1
470 to 1000	0.60	0.88	0.96	1
2200 to 10000	0.75	0.90	0.98	1

Part numbering system (example: 10V1000µF)

Environmental item	RK	—	10	V	102	M	H5	#
	Series code		Rated voltage symbol		Rated capacitance symbol	Capacitance tolerance symbol	Casing symbol	Additional symbol

- Lineup of only environmental item.

- The standard ratings are described on the next page.

Standard Ratings

Rated voltage (V)	Item	10				16				25			
		Case øD x L (mm)	Casing symbol	Impedance (Ω)	Rated ripple current (mA _{rms})	Case øD x L (mm)	Casing symbol	Impedance (Ω)	Rated ripple current (mA _{rms})	Case øD x L (mm)	Casing symbol	Impedance (Ω)	Rated ripple current (mA _{rms})
220	—	—	—	—	8x12	G3	0.26	340	8x15	G4	0.19	480	
330	8x12	G3	0.26	340	10x12.5	H3	0.20	500	10x16	H4	0.15	630	
470	10x12.5	H3	0.20	500	10x16	H4	0.15	630	10x20	H5	0.10	770	
1000	10x20	H5	0.10	770	12.5x20	I 5	0.070	920	12.5x25	I 6	0.050	1250	
2200	12.5x25	I 6	0.050	1250	16x25	J 6	0.042	1380	16x25	J 6	0.042	1380	
3300	16x25	J 6	0.042	1380	18x25	K6	0.041	1450	18x31.5	K7	0.035	1720	
4700	18x25	K6	0.041	1450	18x35.5	K8	0.029	1980	18x35.5	K8	0.029	1980	
10000	18x35.5	K8	0.029	1980	—	—	—	—	—	—	—	—	

Rated voltage (V)	Item	35				50				63			
		Case øD x L (mm)	Casing symbol	Impedance (Ω)	Rated ripple current (mA _{rms})	Case øD x L (mm)	Casing symbol	Impedance (Ω)	Rated ripple current (mA _{rms})	Case øD x L (mm)	Casing symbol	Impedance (Ω)	Rated ripple current (mA _{rms})
47	—	—	—	—	—	—	—	—	8x12	G3	0.68	245	
100	8x12	G3	0.26	340	10x12.5	H3	0.36	415	10x16	H4	0.30	455	
220	10x16	H4	0.15	630	10x20	H5	0.18	655	12.5x20	I 5	0.18	665	
330	10x20	H5	0.10	770	12.5x20	I 5	0.12	780	12.5x25	I 6	0.14	995	
470	12.5x20	I 5	0.070	920	12.5x25	I 6	0.090	1060	16x25	J 6	0.10	1000	
1000	16x25	J 6	0.042	1380	16x25	J 6	0.078	1130	18x31.5	K7	0.084	1280	
2200	18x31.5	K7	0.035	1720	18x35.5	K7	0.051	1720	—	—	—	—	
3300	18x40	K9	0.025	2240	—	—	—	—	—	—	—	—	

(Note) Rated ripple current : 125°C, 100kHz; Impedance : 20°C, 100kHz